



**GLOBAL**  
INDUCTION  
LIGHTING US



**Global Induction Lighting US**

917 SE 14th St, Fort Lauderdale, FL 33316

info@gilus.us • 954-467-8478 • www.gilus.us

EXTERIOR LIGHTING



## Roadway Lighting

Project: \_\_\_\_\_

Part No: \_\_\_\_\_

Quantity: \_\_\_\_\_

IP RATING  
**55**



### GLZD10-150/200/250

#### Features

- ◆ New, high wattage, induction lighting fixture with novel design and excellent aesthetics.
- ◆ High pressure, die cast aluminum housing with powder coated finish for corrosion-resistance.
- ◆ Flat tempered glass lens and heat-resistant silicone rubber seal for high IP rating, dusk to dawn sensor.
- ◆ High purity aluminum reflector with vacuum coated inner surface.
- ◆ EPA Ratings: 150=2.80 ft<sup>2</sup>, 200/250=4.20 ft<sup>2</sup>

#### Lamp and Ballast

- ◆ Globals 150W, 200W or 250W rectangular tubular induction lamp features high lighting efficiency.
- ◆ Note: Total energy consumption=fixture wattage+5% for ballast overhead.
- ◆ Estimated lifespan 100,000 hours.
- ◆ Electronic ballast features high power factor (>0.95), flicker free, instant on/instant re-strike.
- ◆ Engineered to operate efficiently at +130F - Cold weather certified to -40 F.

#### Applications

- ◆ Roadways, parking lots, plazas, public entrances, driveways, off-street areas, etc.

ROADWAY LIGHT



### DIMENSIONS

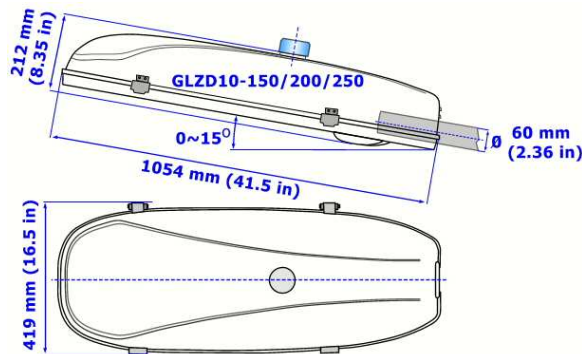

### PHOTOMETRICS

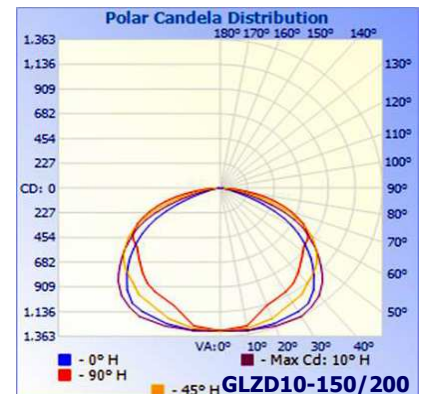

GLZD10 - 150/200/250



### FIXTURE SPECIFICATIONS

Global Code	Type	Lamp	Voltage	Colour Temp.#	Note
GLZD10-150	Roadway Light	150W - Rectangular	120~277	6,500K #Colour temperatures of 4100K or 6500K available by special order	Includes Photo sensor.
GLZD10-200		200W - Rectangular			
GLZD10-250		250W - Rectangular			